

mini FLOWATCH® 2

SICCOM

Mini solenoid pump reliable and silent for the condensate removal of air conditioners up to 10kW / 36000BTU.

Ref: DE05LC4400



PREMIUM

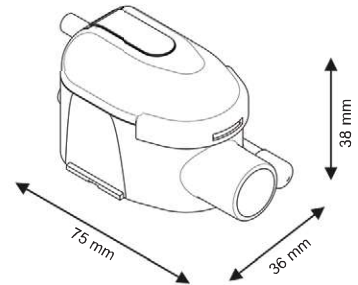
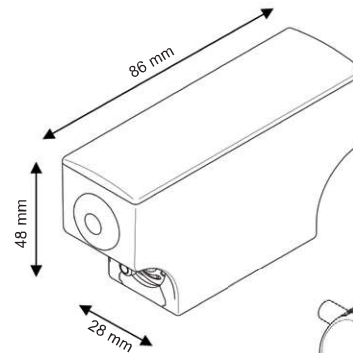

Hose diameter
Suction : 5/7 mm - supplied
Discharge : 6/9 mm - not supplied

SPECIFICATIONS

Flowrate max	15 l/h
Suction head max	2 m
Discharge head max	10 m
Electrical power	19W
Voltage	220-240V 50/60Hz
Alarm	NO-NC
Noise level	
Protection rating	IP64
Thermal protection	Yes
Operating cycle*	100%
Power / alarm cable	1.6 m
Dimensions	86 x 28 x 48 mm / 75 x 38 x 36 mm
Certifications	CE, UKCA, EAC, CMIM

* The pump is able to run 100% of the time if necessary.

FLOWRATE

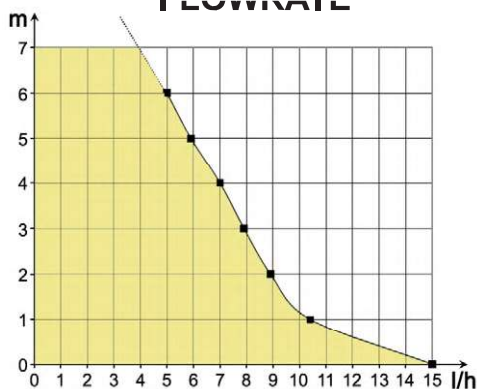

Recommended accessory



Kit COMFORT

Thanks to its patented foam casing, this kit reduces the noise level and makes the pump easier to install.

Ref: GC077G1027

BENEFITS



Very silent

Very silent pump (20.2 dBA), suitable for an installation in any room.



IP64 protection

Protected against water splashes and dust.



Plug & Play connectors

Make installation and maintenance easier.



Clear reservoir

Facilitates maintenance thanks to a quick visualization of the reservoir state.



Metal pump outlets

High solidity and reliability.



Accessories included

All accessories required for installation are included in the box.



Stop siphoning included **NEW**

Allows to avoid all risk of negative discharge and to secure the pump functioning over time.

CONTENTS



Pump - Reservoir with air-vent tube - Power / alarm cable - Reservoir stand - Stop Siphoning - Double-side adhesive - Inlet tube - Suction tube 1.8m - 1 clamp